

MULTIMATERIALS COUPLING WITH GFIX® GRIP SYSTEM DN 50 - 400 PN10/16

08.400



Product description

- Multimaterial coupling with GFIX® grip system for drinking water and neutral liquids
- Service temperature from 0°C (excluding frost) to 70°C

Standards

- Designed according to EN 14525

Test according

- EN 14525: Positive internal pressure and negative internal
- EN 545: Positive internal pressure

Corrosion protection

- Epoxy powder coating RAL 5005
- Applied internal and external with a minimum coating thickness of 250 µm
- Potable water approved epoxy coating, fusion bonded according EN 14901 and GSK approved

Approvals

- GSK Epoxy Coating Certificate GSK-ID:1247 (RAL-GZ 662)

Features

- Multimaterials coupling for drinking water
- GFIX® system allows a high-fidelity seal/locking of the assembly without pipe disconnections
- The pipe block is performed by a tempered serrated rivets system mounted on the conical claws that fit and grip causing no damage on the pipe
- Sealing system with drinking water approved EPDM
- The sealing is carried out through a seal with O-rings, mounted on a ring made by the grip support, which will slide until being pressed against the pipe
- Allows a maximum angle deflection of 8°
- Bolts and washers in stainless steel A2 and nuts in stainless steel A4 with anti-friction coated protection
- Bolts ends protected with plastic caps
- Allow the connection between pipes with several external diameters and different materials (PE, uPVC, ductile iron, steel, abestos ciment, glass fiber pipes and others)
- For PE or uPVC pipe applications, should be used an insert in stainless steel (ref.15.400)
- On request possibility of bolts, washers and nuts in stainless steel A4.

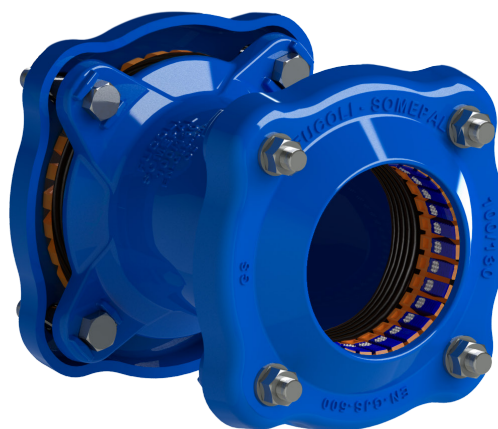

RAI GUTZEICHEN
SCHWEISZ KENNZEICHEN
VON ARMATUREN UND FORMSTÜCKEN



Fucoli Somepal
FUNDAÇÃO DE FERRO, S. A.

Visit our website at www.fucoli-somepal.pt

Head office: Estrada de Coselhas, 3000-125 Coimbra – Portugal | Tel.: (+351) 239 490100 | Fax: (+351) 239 490198

Branch office: Rua de Aveiro 50, 3050-420 Pampilhosa – Portugal | Tel.: (+351) 239 490100 | Fax: (+351) 231 949292 | comercial@fucoli-somepal.pt

MULTIMATERIALS COUPLING WITH GFIX® GRIP SYSTEM DN 50 - 400 PN10/16

08.400

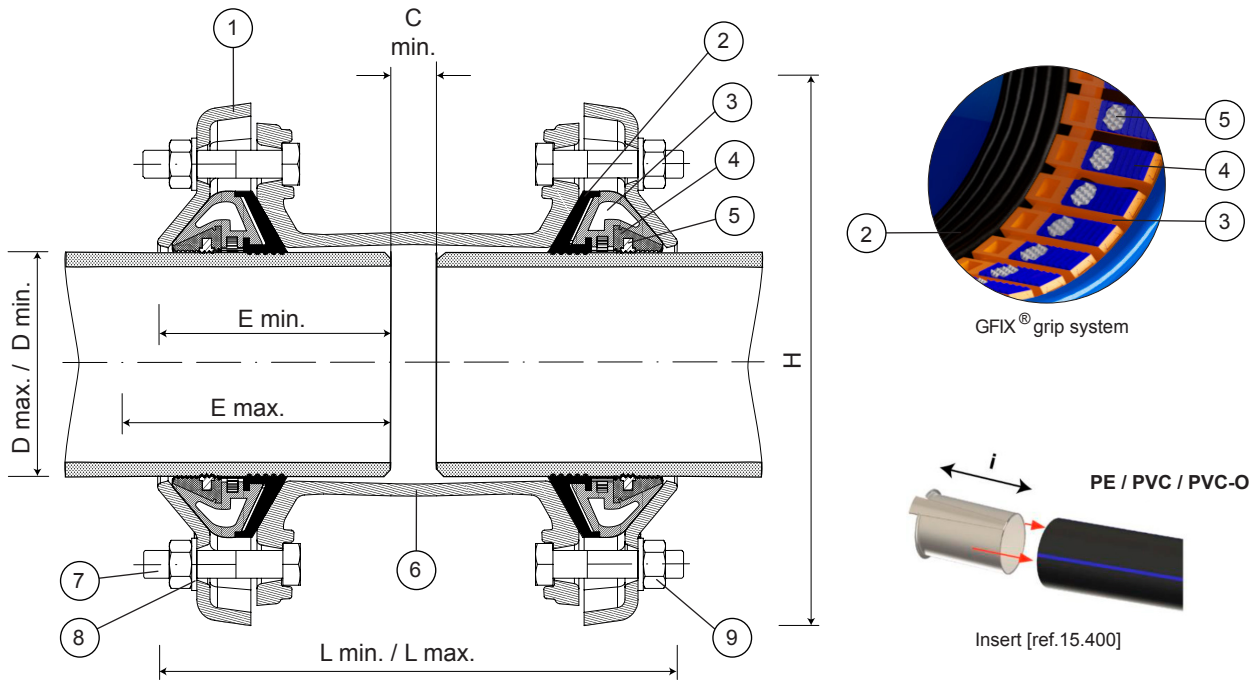

Component list

pos.	components	material	standard
1	Locking ring	Ductile iron EN-GJS-500-7	EN 1563
2	Sealing	Elastomer EPDM	EN 681 - 1
3	Gripper support	POM	-
4	Gripper	POM	-
5	Rivets with milling	Tempered steel cq 15	DIN 1654

pos.	components	material	standard
6	Body	Ductile iron EN-GJS-500-7	EN 1563
7	Bolts	Stainless steel A2	EN 10088 - 1
8	Nuts	Stainless steel A4	EN 10088 - 1
9	Washers	Stainless steel A2	EN 10088 - 1

Reference and dimensions

DN	D		L	H	E	C	Kg	i			
mm	min./max. mm - mm	code	min./max. mm - mm	mm	min./max. mm - mm	min. mm	approx.	insert* mm	Bolt		Torque
50	39 - 52	10900400	233 - 250	162	90 - 115	20	6	175	M12	19 mm	50 - 70 Nm
50	49 - 64	10900401	231 - 250	175	90 - 115	20	6	175	M12	19 mm	50 - 70 Nm
65	63 - 83	10900402	258 - 286	209	105 - 133	20	12	175	M12	19 mm	50 - 70 Nm
80	72 - 93	10900424	257 - 286	217	105 - 133	20	13	175	M12	19 mm	50 - 70 Nm
80	78 - 103	10900403	250 - 286	229	105 - 133	20	14	175	M12	19 mm	50 - 70 Nm
100	87 - 117	10900404	244 - 286	243	105 - 133	20	15	175	M12	19 mm	50 - 70 Nm
100	100 - 130	10900405	253 - 299	256	105 - 140	20	16	175	M16	24 mm	90 - 120 Nm
125	117 - 147	10900406	253 - 299	273	105 - 140	20	19	175	M16	24 mm	90 - 120 Nm
150	138 - 168	10900407	253 - 299	294	105 - 140	20	21	175	M16	24 mm	90 - 120 Nm
150	152 - 182	10900408	288 - 330	308	115 - 155	20	21	200	M16	24 mm	90 - 120 Nm
175	172 - 202	10900409	288 - 330	325	115 - 155	20	23	200	M16	24 mm	90 - 120 Nm
200	198 - 228	10900410	288 - 330	354	115 - 155	20	28	200	M16	24 mm	90 - 120 Nm
225	217 - 257	10900411	300 - 359	392	130 - 170	20	32	225	M16	24 mm	90 - 120 Nm
250	245 - 285	10900412	383 - 440	434	150 - 210	20	39	225	M16	24 mm	90 - 120 Nm
300	300 - 340	10900413	383 - 440	479	150 - 210	20	51	225	M16	24 mm	90 - 120 Nm
350	340 - 380	10900414	383 - 440	519	150 - 210	20	55	225	M16	24 mm	90 - 120 Nm
400	390 - 430	10900415	383 - 440	571	150 - 210	20	70	225	M16	24 mm	90 - 120 Nm

* recommended for PE, uPVC or PVC-O pipes



Fucoli Somepal
FUNDAÇÃO DE FERRO, S. N.

Visit our website at www.fucoli-somepal.pt

Head office: Estrada de Coselhas, 3000-125 Coimbra – Portugal | Tel.: (+351) 239 490100 | Fax: (+351) 239 490198

Branch office: Rua de Aveiro 50, 3050-420 Pampilhosa – Portugal | Tel.: (+351) 239 490100 | Fax: (+351) 231 949292 | comercial@fucoli-somepal.pt



100% MADE IN EUROPE